

For each question from 1 to 28, four options are given. One of them is the correct answer. Make your choice (1, 2, 3 or 4) and shade your answer on the Optical Answer Sheet.

(56 marks)

- 1 Lucy is pregnant. Besides her reproductive system, which two organ systems in her body work together to provide nutrients for her developing baby?

- A Muscular system
- B Digestive system
- C Circulatory system
- D Respiratory system

- (1) A and C only
- (2) B and C only
- (3) B and D only
- (4) A and D only

- 2 The roots of a plant _____.

- A support the plant
- B can store food for the plant
- C hold the plant firmly to the soil
- D absorb water and mineral salts from the soil

- (1) D only
- (2) A and C only
- (3) B, C and D only
- (4) A, B, C and D

- 3 Which of the following show(s) the correct comparison of gases between inhaled air and exhaled air in the human body?

| | Gas | Inhaled Air | Exhaled Air |
|---|----------------|-------------|-------------|
| A | Oxygen | More | Less |
| B | Nitrogen | Less | More |
| C | Water vapour | Same | Same |
| D | Carbon dioxide | More | Less |

- (1) A only
- (2) A and C only
- (3) A and D only
- (4) B and C only

4 Study the flowchart.

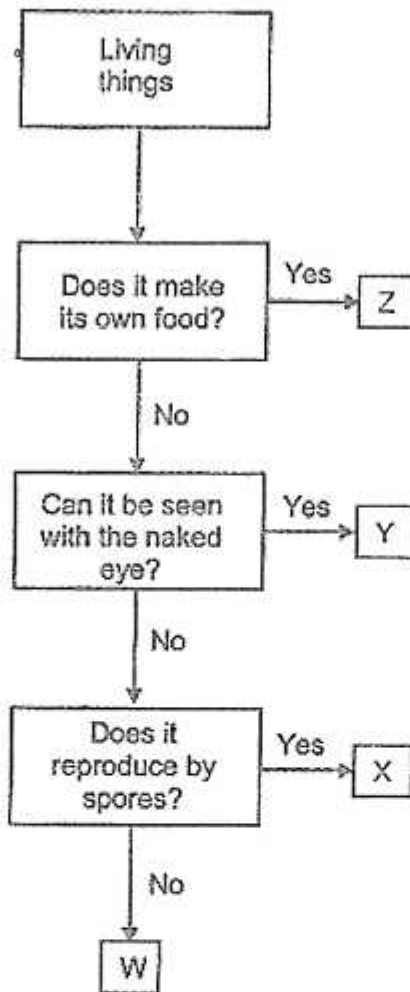

Which of the following correctly identifies the living things represented by W, X, Y and Z?

| | W | X | Y | Z |
|-----|-------------|-------------|-------------|-------------|
| (1) | Bread mould | Bacteria | Orchid | Mushroom |
| (2) | Orchid | Mushroom | Bread mould | Bacteria |
| (3) | Bacteria | Bread mould | Mushroom | Orchid |
| (4) | Mushroom | Orchid | Bacteria | Bread mould |

- 5 Jeffri placed a healthy potted plant in a sealed glass container and placed it in the garden. He recorded the amount of carbon dioxide in the container at regular intervals over 24 hours and plotted the graph as shown.

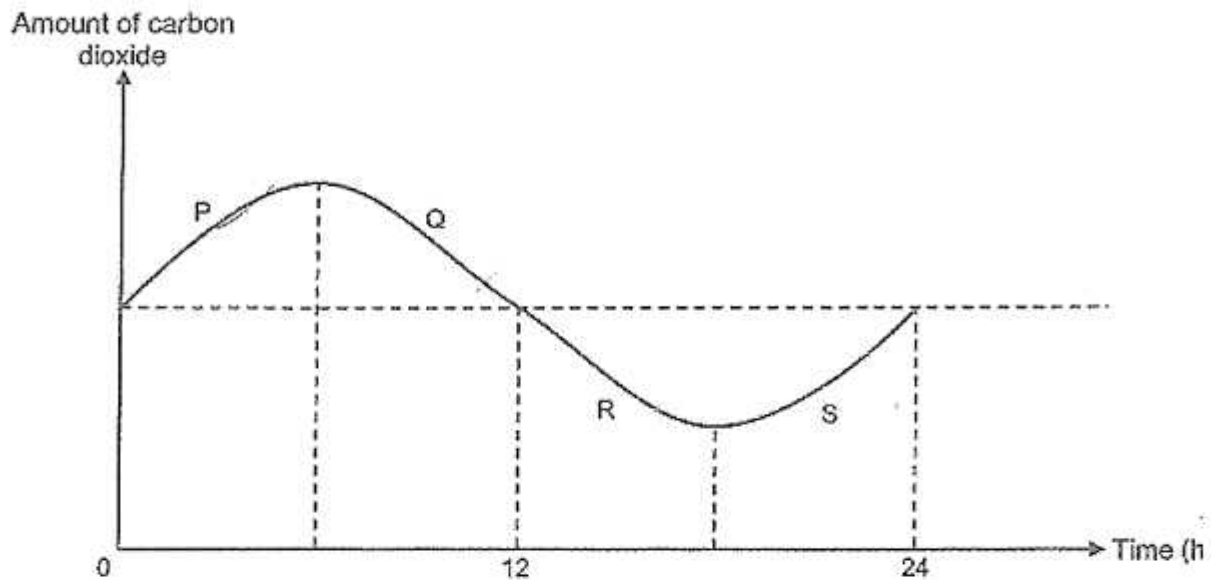

Which parts of the graph show respiration and photosynthesis taking place in the plant?

| | Respiration | Photosynthesis |
|-----|---------------|----------------|
| (1) | P and Q | R and S |
| (2) | P and S | Q and R |
| (3) | P, Q, R and S | Q and R |
| (4) | P, Q, R and S | R and S |

6 A tick (✓) in the table indicates the presence of a cell part in cells W, X, Y and Z.

| Cell Part | Cell W | Cell X | Cell Y | Cell Z |
|---------------|--------|--------|--------|--------|
| Nucleus | ✓ | ✓ | ✓ | |
| Cytoplasm | ✓ | ✓ | ✓ | ✓ |
| Cell membrane | ✓ | ✓ | ✓ | ✓ |
| Cell wall | | ✓ | ✓ | |
| Chloroplast | | | ✓ | |

Which two statements are correct?

- A Cells W and Z are plant cells.
- B Cell Y is able to photosynthesize.
- C Cell X could be taken from the root of a plant.
- D Cell W has a fixed shape but Cell Y does not.

- (1) A and B
- (2) A and D
- (3) B and C
- (4) C and D

7 The diagram shows a leaf on a plant.

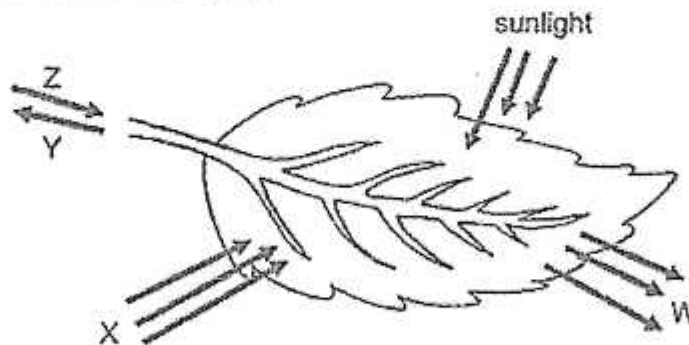

What are substances W, X, Y and Z?

| | W | X | Y | Z |
|-----|----------------|----------------|---------|---------|
| (1) | carbon dioxide | oxygen | water | starch |
| (2) | oxygen | carbon dioxide | water | glucose |
| (3) | carbon dioxide | oxygen | starch | water |
| (4) | oxygen | carbon dioxide | glucose | water |

8 The diagram shows some animals.

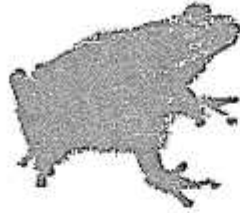

Frog

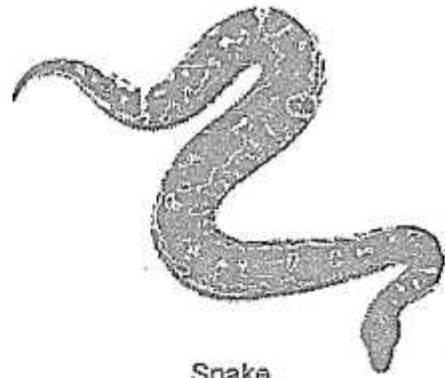

Snake

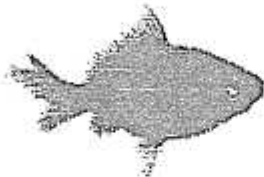

Goldfish



Cockroach

Which of the following statements are correct?

- A Only the goldfish has scales.
 - B Only the cockroach has six legs.
 - C The frog and snake have moist skin.
 - D All four animals reproduce by laying eggs.
-
- (1) A and C only
 - (2) B and D only
 - (3) A, C and D only
 - (4) B, C and D only

- 9 Aria set up four containers, A, B, C and D, with 20g of oats and a mealworm larva in each of the four containers at the Science lab. He recorded the amount of oats left in each container over four days.

| Container | Amount of oats left (g) | | | |
|-----------|-------------------------|--------------|--------------|--------------|
| | End of day 1 | End of day 2 | End of day 3 | End of day 4 |
| A | 18 | 13 | 6 | 6 |
| B | 17 | 9 | 8 | 7 |
| C | 16 | 8 | 8 | 8 |
| D | 15 | 14 | 11 | 9 |

Which container did the larva develop into a pupa first?

- (1) A
 (2) B
 (3) C
 (4) D
- 10 Mark made the following statements about a germinating seed and an adult plant.
- A They need air, water and sunlight.
 B They get food from the seed leaves.
 C They take in water through the roots.

Which statement(s) is/are true for both the germinating seed and the adult plant?

- (1) C only
 (2) A and B only
 (3) A and C only
 (4) B and C only

- 11 Julian conducted an experiment by releasing fruit A from a height of five meters. The fruit landed at a distance, X , as shown in the diagram.

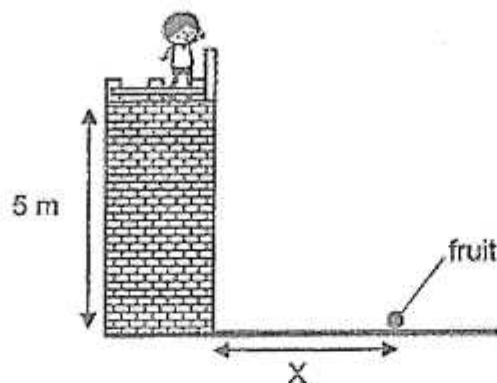

He repeated the experiment with fruit B and recorded the results in the table.

| Fruit | A | B |
|--------------------|----|-----|
| Distance, X (cm) | 60 | 500 |

Which characteristic of fruit B allowed it to travel a further distance than fruit A?

- (1) Hooks
- (2) Fibrous husk
- (3) Wing-like structure
- (4) Sweet and juicy flesh

12 Study the flowchart.

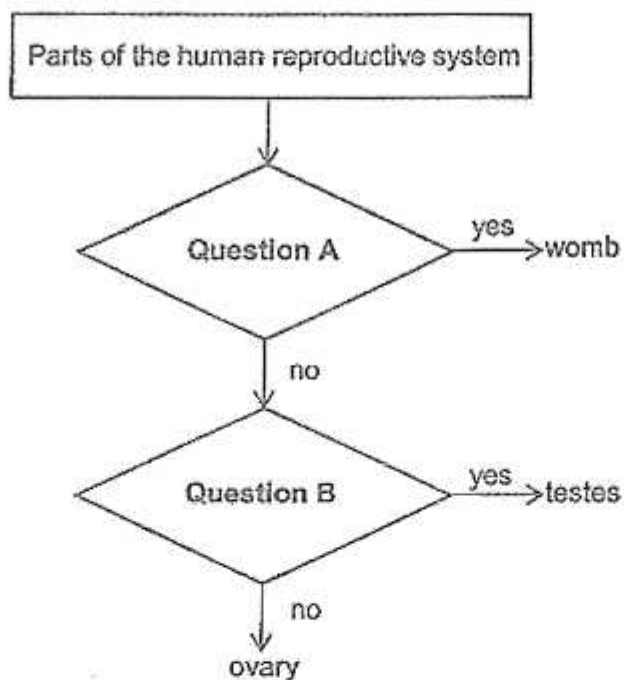

Which of the following is correct?

| | Question A | Question B |
|-----|---------------------------------------|-------------------------|
| (1) | Does it receive the sperm? | Does it produce sperms? |
| (2) | Does it receive the sperm? | Does it produce eggs? |
| (3) | Does the fertilised egg develop here? | Does it produce sperms? |
| (4) | Does the fertilised egg develop here? | Does it produce eggs? |

- 13 The diagram shows a circuit board. The wires connecting the battery to the bulb holders X, Y and Z, are hidden under the wooden board.

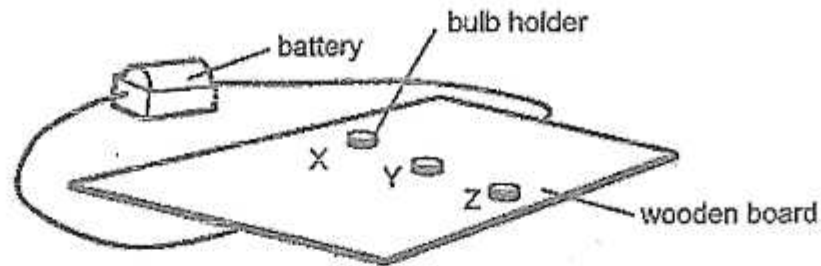

Calvin tried to find out how X, Y and Z were connected using two identical light bulbs. The bulbs would light up when they are placed in bulb holders that are connected in a closed circuit. He recorded his observations in the table as shown.

| When no bulb was placed in bulb holder | Observations |
|--|-----------------------------------|
| X | bulbs at Y and Z lit up |
| Y | bulbs at X and Z lit up |
| Z | bulbs at X and Y did not light up |

Which of the following shows the correct circuit that is under the wooden board?

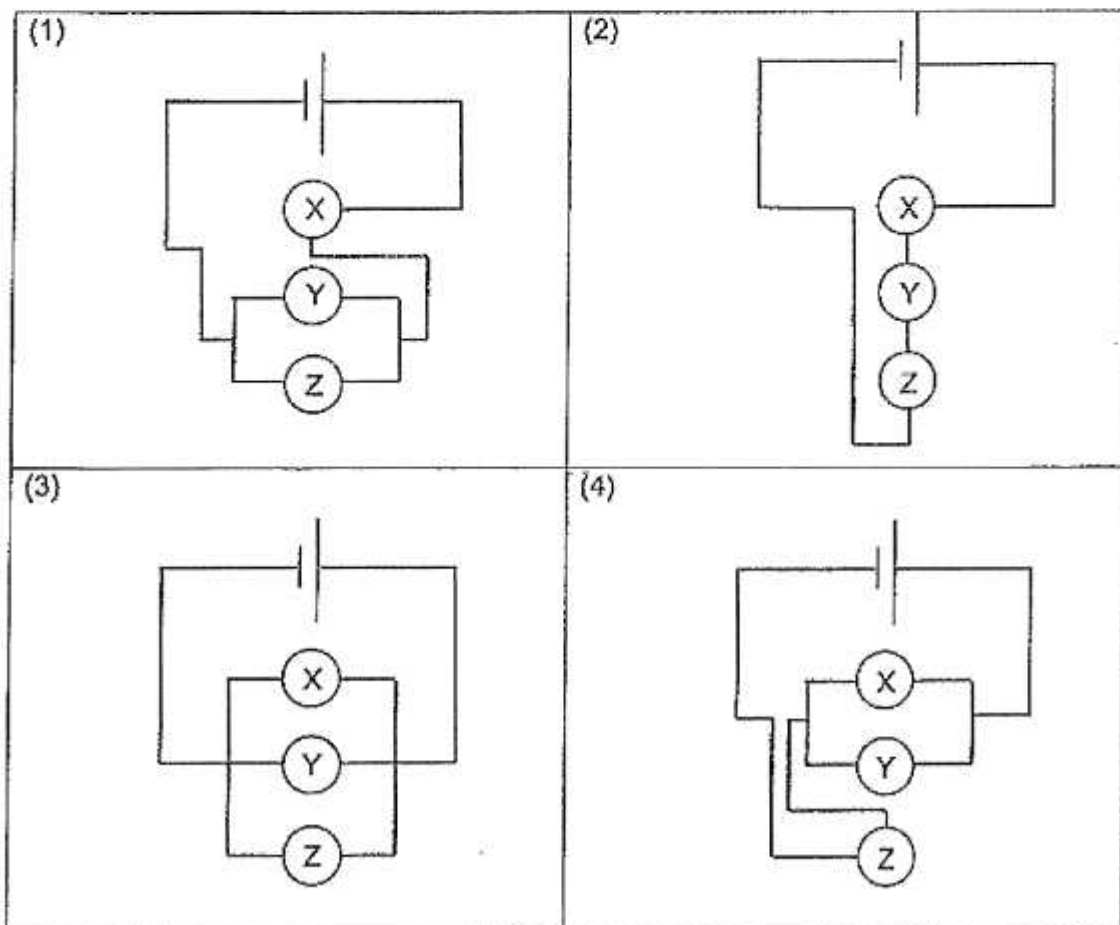

- 14 The following circuits are set up using identical batteries and bulbs, which are in working condition.

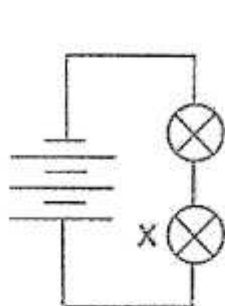

Circuit R

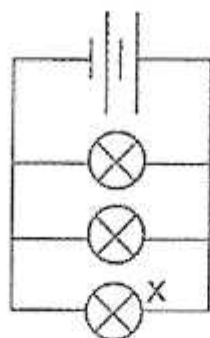

Circuit S

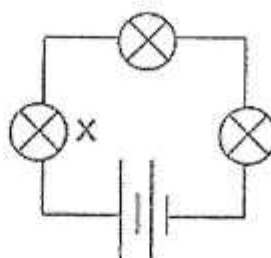

Circuit T

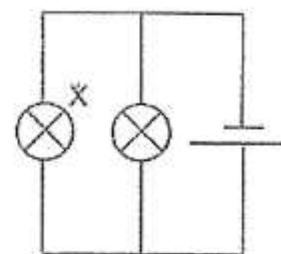

Circuit U

Which of the following shows the order of the brightness of bulb X in each circuit, from the brightest to the dimmest?

- (1) T, U, R, S
 - (2) R, S, T, U
 - (3) S, R, U, T
 - (4) U, T, S, R
- 15 Anna heated a beaker of ice. The graph shows the changes in the temperature of the contents in the beaker over 20 minutes.

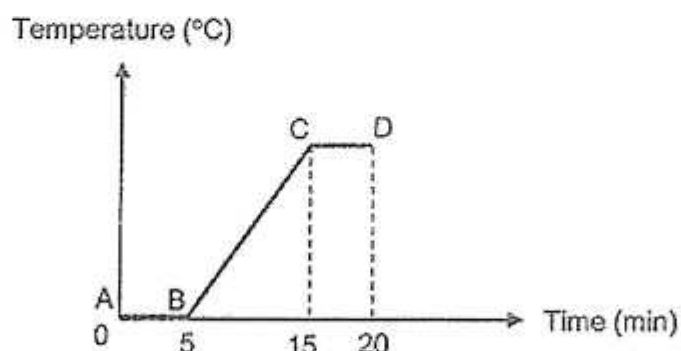

Which part(s) of the graph show(s) when the contents in the beaker gained heat and changed state?

| | Gained heat | Changed state |
|-----|---------------|---------------|
| (1) | BC | AB and BC |
| (2) | AB and BC | BC and CD |
| (3) | AB, BC and CD | AB and CD |
| (4) | AB, BC and CD | AB, BC and CD |

- 16 The table shows the freezing points and boiling points of two substances, P and Q.

| Substance | Freezing Point (°C) | Boiling Point (°C) |
|-----------|---------------------|--------------------|
| P | 110 | 190 |
| Q | 50 | 230 |

Which are the correct states of substances P and Q at 80°C?

| | P | Q |
|-----|--------|--------|
| (1) | Solid | Solid |
| (2) | Solid | Liquid |
| (3) | Liquid | Liquid |
| (4) | Liquid | Solid |

- 17 The ball and ring shown in the diagrams are made of iron.

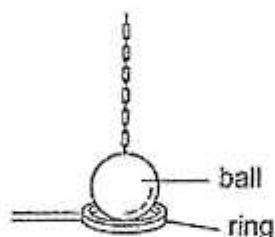

Diagram 1

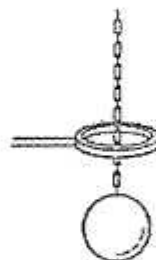

Diagram 2

In Diagram 1, the ball was unable to pass through the ring at room temperature. In Diagram 2, the ball was able to pass through the ring after heating the ring over a Bunsen burner for 10 minutes.

Why could the ball pass through the ring?

| | Ball | Ring |
|-----|------------------------|------------------------|
| (1) | expanded | remained the same size |
| (2) | expanded | contracted |
| (3) | remained the same size | expanded |
| (4) | contracted | expanded |

- 18 Ronaldo placed a humidifier in his bedroom which releases mist into the air as shown.

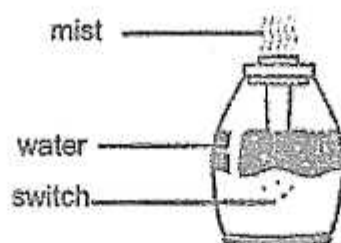

After his shower, Ronaldo switched off the humidifier when he entered his bedroom.

Which of the following explains why he switched it off?

- (1) This will cause the water on his skin to lose heat to the surrounding mist and evaporate faster.
- (2) This will lower the temperature of the surrounding air, increasing the rate of evaporation of water from his skin.
- (3) This will increase the amount of water vapour in the surrounding air, increasing the rate of condensation of water vapour from his skin.
- (4) This will not further increase the amount of water vapour in the surrounding air, allowing the rate of evaporation of water from his skin to increase.

- 19 Samuel conducted an experiment using identical beakers and metal dishes as shown. He filled the beakers with the same volume of water at different temperatures.

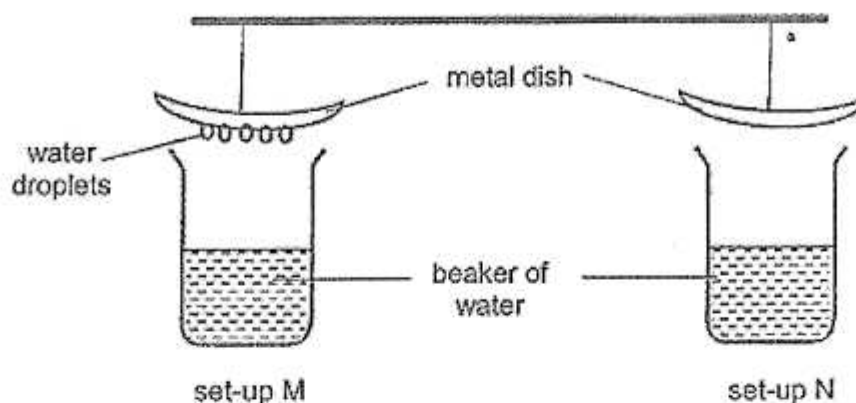

After a few minutes, he noticed water droplets forming only on the underside of the metal dish in set-up M.

Which of the following explains why water droplets did not form on the underside of the metal dish in set-up N?

- (1) Temperature of water in set-up N is 100°C .
 - (2) The maximum rate of condensation has been reached.
 - (3) Temperature of metal dish in set-up N is lower than the surrounding air.
 - (4) The metal dish in set-up N is at the same temperature as the surrounding air.
- 20 Which is/are renewable source(s) of energy?
- A Coal
 - B Wind
 - C Sunlight
 - D Natural gas
- (1) A only
 - (2) B and C only
 - (3) B, C and D only
 - (4) A, B, C and D

- 21 The set-up shows a torch shining light on three objects A, B and C made of cardboard. The objects are placed at different distances from the torch light.

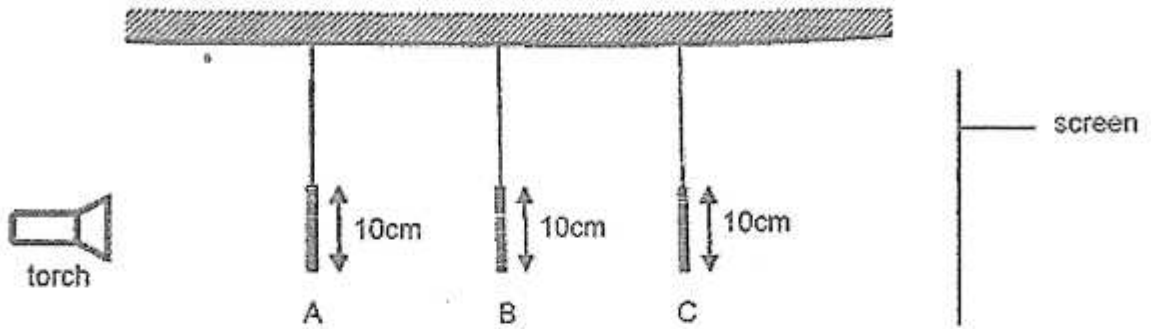

The diagram shows what was seen on the screen.

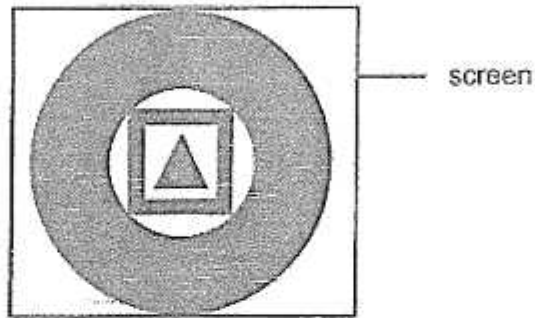

Which of the following correctly represents objects, A, B and C?

| | A | B | C |
|-----|---|---|---|
| (1) | | | |
| (2) | | | |
| (3) | | | |
| (4) | | | |

- 22 Diagram 1 shows a container filled with three different substances, R, S and T. Diagram 2 shows the same container filled with more of substance S.

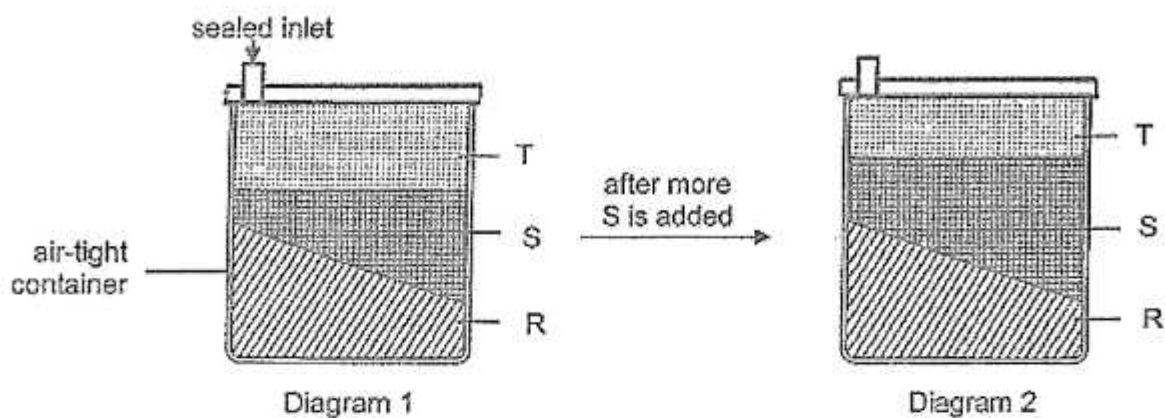

Based on your observation of the diagrams, which are the states of matter of substances R, S and T?

| | Substance R | Substance S | Substance T |
|-----|-------------|-------------|-------------|
| (1) | Solid | Gas | Liquid |
| (2) | Solid | Liquid | Gas |
| (3) | Liquid | Gas | Solid |
| (4) | Liquid | Solid | Gas |

23 Lucien set up an experiment as shown.

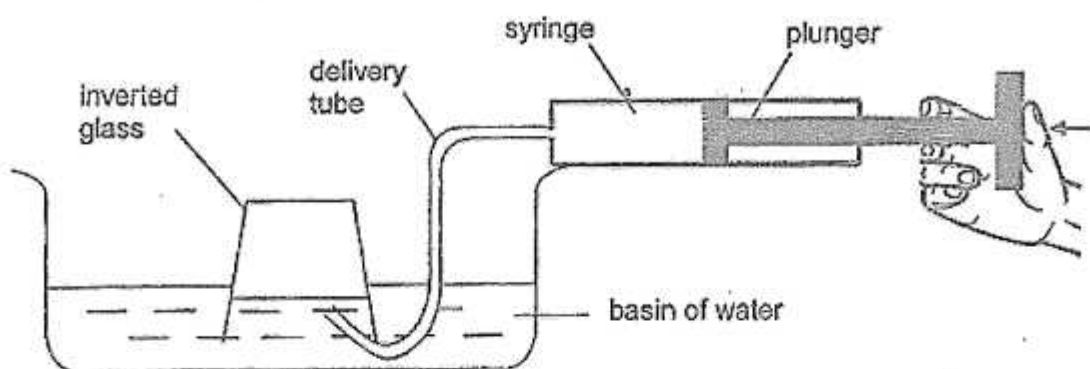

After Lucien pushed the plunger in three times, he observed that the water level in the glass decreased as the water level in the basin increased. What properties of air and water were observed?

- A Air takes up space.
- B Water takes up space.
- C Air can be compressed.
- D Water has an indefinite shape.

- (1) A and B only
- (2) A and C only
- (3) A, B and D only
- (4) B, C and D only

- 24 Nathan set up an experiment to find out which objects, A, B and/or C, are magnets. He labelled the two ends of each object, X and Y. He brought the ends of each object near the North pole of a freely suspended magnet and recorded his findings in a table.

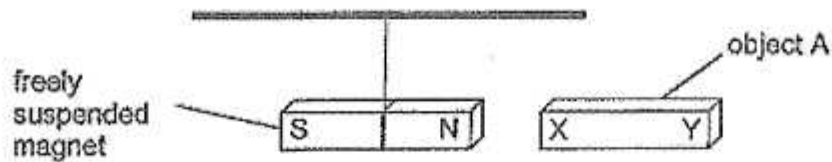

| Object | End | Interaction with magnet | |
|--------|-----|-------------------------|----------|
| | | Attracted | Repelled |
| A | X | ✓ | |
| | Y | ✓ | |
| B | X | | ✓ |
| | Y | ✓ | |
| C | X | ✓ | |
| | Y | | ✓ |

Nathan can conclude that object(s) _____ is/are magnets.

- (1) A only
- (2) A and C only
- (3) B and C only
- (4) A, B and C

- 25 Matthew set up an experiment to find out how the thickness of material Q affects the magnetic force acting on the paper clip.

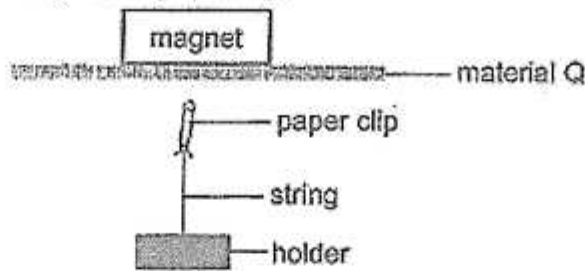

Which two actions must Matthew take to test the aim of his experiment?

- A Use different thicknesses of material Q.
- B Use different magnets throughout the experiment.
- C Use the same paper clip throughout the experiment.
- D Vary the distance between the paper clip and material Q.

- (1) A and B
 (2) A and C
 (3) B and C
 (4) B and D
- 26 When Alex placed two identical objects, X and Y, on two springs of the same length, P and Q, spring Q compressed more than spring P as shown.

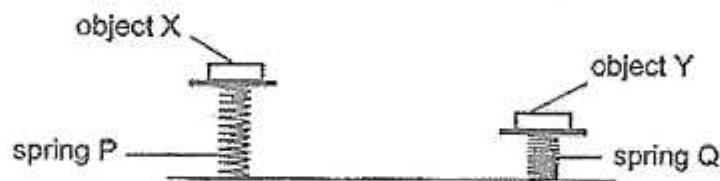

Which of the following statements are true?

- A Spring P is more stiff than spring Q.
- B Spring Q has a greater mass than spring P.
- C Elastic spring force is acting on objects X and Y.
- D There was more force acting on spring Q than spring P.

- (1) A and B only
 (2) A and C only
 (3) B and D only
 (4) A, C and D only

- 27 An iron ball is released from the top of a plastic ramp which has a strong magnet attached to its underside as shown.

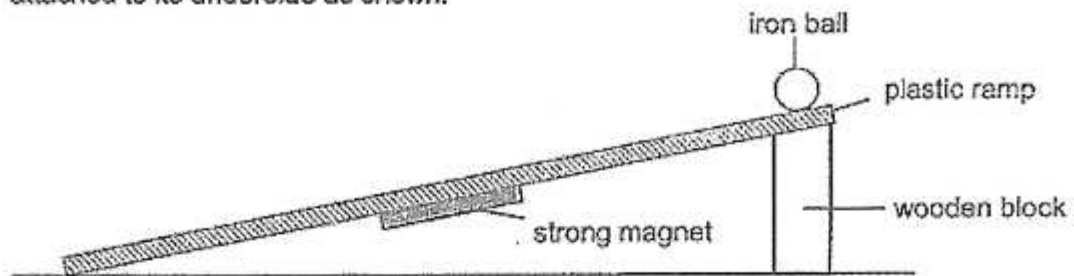

Which forces are acting on the iron ball as it rolls down the ramp?

- A Kinetic force
 - B Magnetic force
 - C Frictional force
 - D Gravitational force
- (1) A and D only
 (2) B and C only
 (3) B, C and D only
 (4) A, B, C and D

- 28 The diagram shows a flight of stairs.

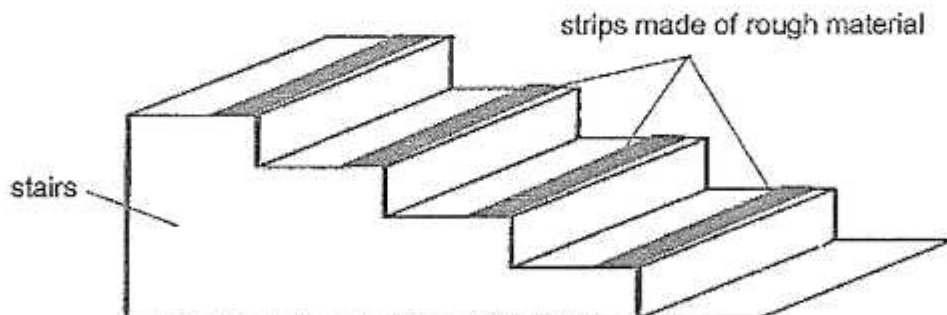

How do the strips prevent Tom from falling?

- (1) They will not break when stepped on.
- (2) They reduce the gravitational force acting on him.
- (3) They act as lubricant to increase the amount of friction.
- (4) They increase friction between the soles of his shoes and the surface of the stairs.

End of Booklet A

For questions 29 to 40, write your answers in this booklet.

The number of marks available is shown in brackets [] at the end of each question or part question. [44 marks]

29. The diagram shows the human digestive system.

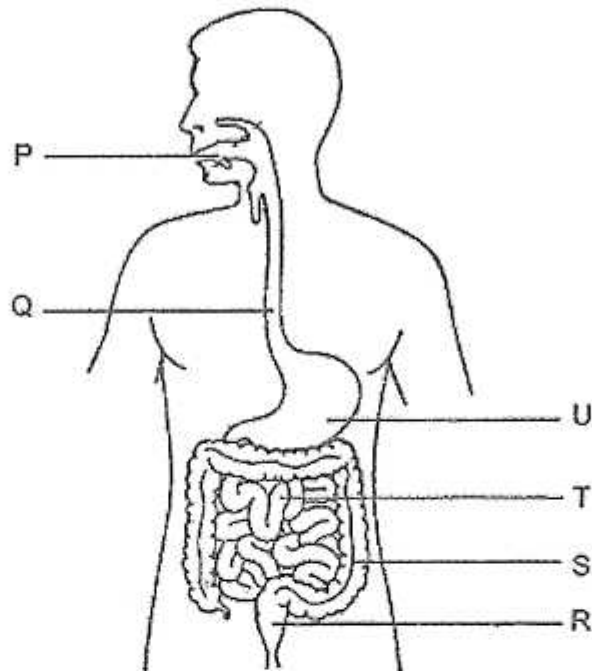

(a) At which part(s) P, Q, R, S, T and/or U is/are digestive juices produced? [1]

(b) Describe what happens to the partially digested food at part T. [2]

(c) What is the function of part S? [1]

(Go on to the next page)

| | |
|-------|---|
| SCORE | 4 |
|-------|---|

30. The diagrams show the circulatory systems of a fish and a human. The arrows represent the movement of blood in each system.

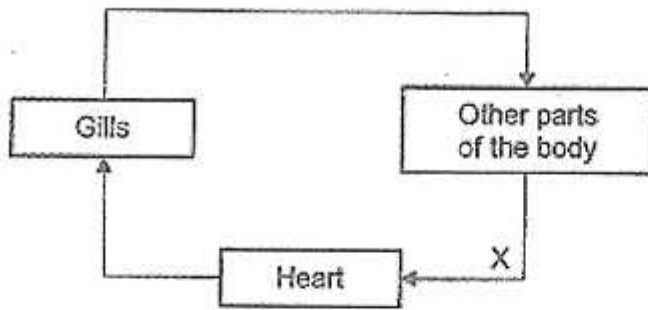

Fish Circulatory System

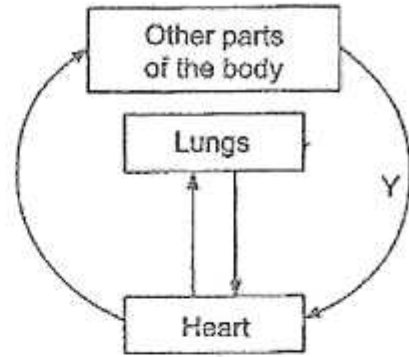

Human Circulatory System

- (a) State how oxygen is absorbed into the blood in each of the systems. [2]

Fish Circulatory System: _____

Human Circulatory System: _____

- (b) The blood at X and Y is poor in oxygen. Explain why. [1]

(Go on to the next page)

| | |
|-------|---|
| SCORE | 3 |
|-------|---|

31. Jonathan recorded the number of young plants, S and T, at various distances from their parent plants in the table shown.

| Distance from parent plant (m) | Number of young plant S | Number of young plant T |
|--------------------------------|-------------------------|-------------------------|
| 2 | 8 | 2 |
| 4 | 2 | 3 |
| 6 | 0 | 7 |
| 8 | 0 | 6 |

- (a) Explain why growing further away from the parent plants benefits the young plants. [1]

- (b) The diagram shows two fruits, X and Y.



Fruit X

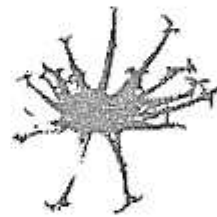

Fruit Y

- Based on your observation of the characteristics of the fruits, which fruit, X or Y, is likely to be from plant T? Explain your answer. [2]

(Go on to the next page)

| | |
|-------|---|
| SCORE | 3 |
|-------|---|

32. Ayden wanted to find out which material, plastic, paper or fabric, can hold the most mass before tearing. He set up the experiment as shown

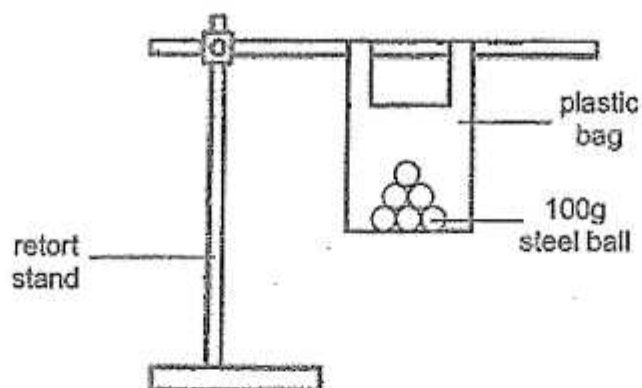

He added steel balls of mass 100 g to each bag until it tore.

- (a) State a hypothesis for Ayden's experiment. [1]

He recorded the results in the table.

| Material of bag | Number of steel balls added before the bag tore |
|-----------------|---|
| Plastic | 48 |
| Paper | 25 |
| Fabric | 83 |

- (b) State two common properties of plastic and fabric that make them suitable for making bags to carry things. [1]

- (c) Based on the results of the experiment, which is the best material for making a bag to carry things? Explain your answer. [1]

(Go on to the next page)

| | |
|-------|---|
| SCORE | 3 |
|-------|---|

33. Tom designed the following circuit for an apartment with a living room, bedroom and bathroom.

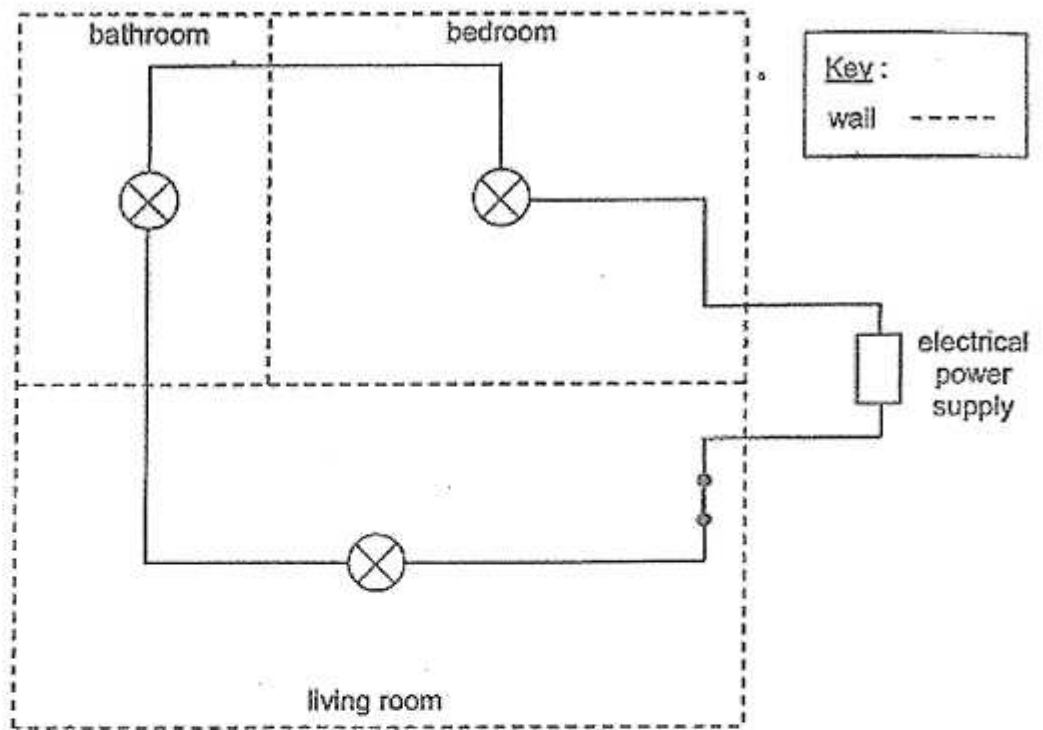

(a) List two disadvantages of this circuit and explain your answer. [2]

1:

2:

(Go on to the next page)

| | |
|-------|---|
| SCORE | / |
| | 2 |

- (b) Complete the following circuit diagram using only switches and wires to address the disadvantages in (a). [1]

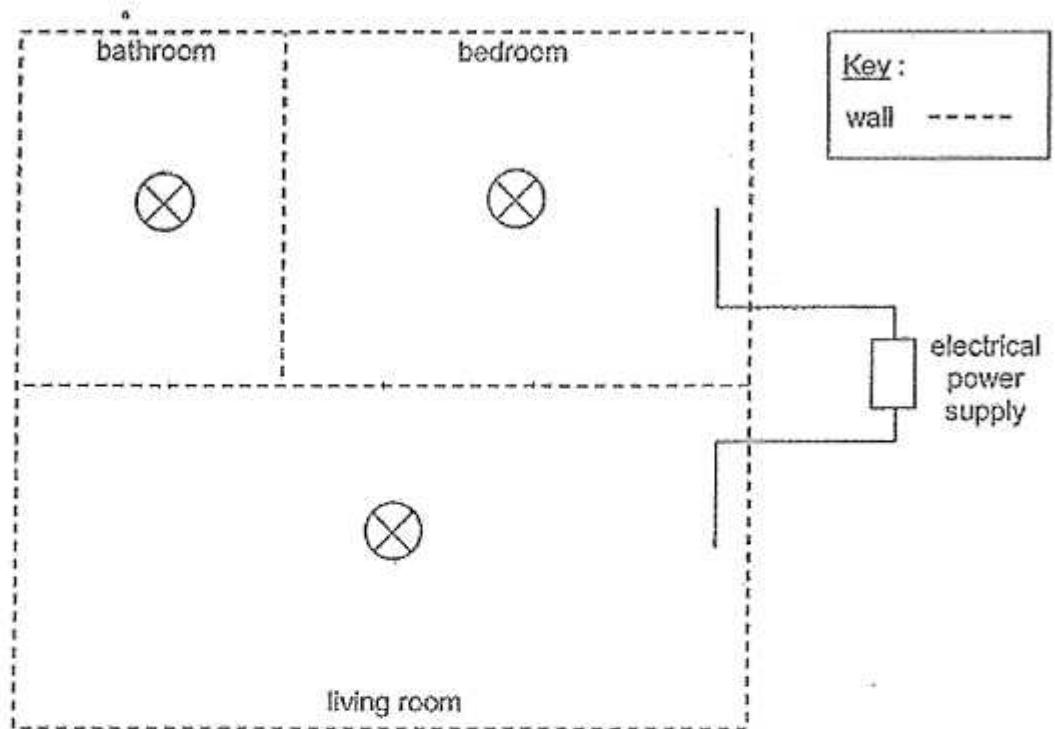

- (c) Tom wants to add an additional switch so that all the lights in the apartment can be switched off at the same time from his bedroom. Draw on your circuit in (b) an "X" to mark the position of this additional switch. [1]

(Go on to the next page)

| | |
|-------|---|
| SCORE | 2 |
|-------|---|

34. Sally bought a cup of hot coffee from a fast food restaurant that came with two different types of removable cardboard sleeves, X and Y.

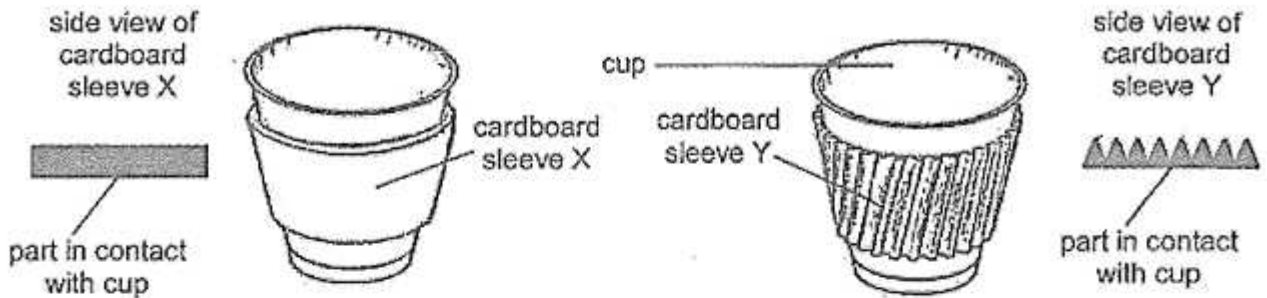

- (a) Sally found that she could hold onto the cup of hot coffee with sleeve Y longer than sleeve X. Explain why. [2]

On her birthday, Sally was given a double-walled glass as shown.

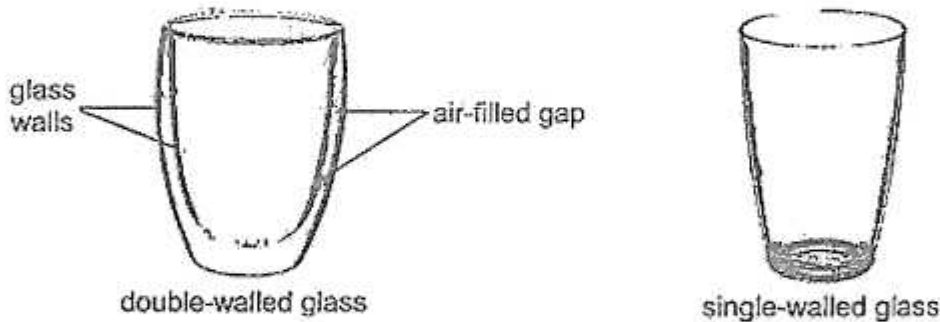

- (b) Sally was told that the double-walled glass would keep a cold drink cold for a longer time than a single-walled glass. Explain why.

- (c) State an advantage of using a single-walled glass instead of a double-walled glass to contain a hot drink. [1]

(Go on to the next page)

| | |
|-------|---|
| SCORE | 5 |
|-------|---|

35. Jack prepared the set-up shown.

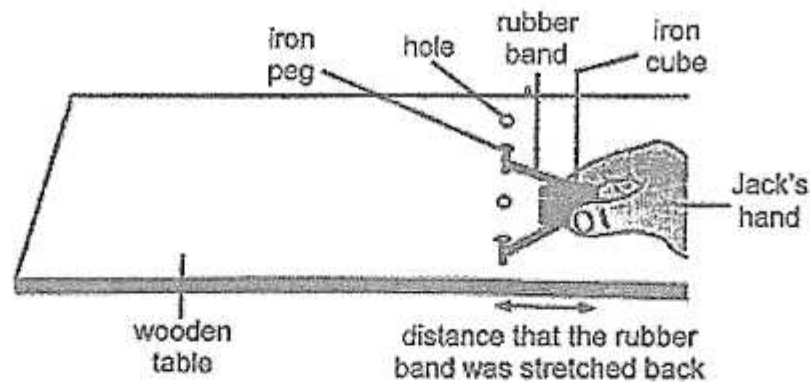

He used the same iron cube and stretched the rubber band to different distances. He recorded the distance travelled by the cube on the surface of the table each time the rubber band was released.

| Distance that the rubber band was stretched back (cm) | Distance travelled by the iron cube (cm) |
|---|--|
| 4 | 6 |
| 6 | 12 |
| 8 | 17 |
| 10 | 21 |
| 12 | 25 |

- (a) Fill in the blanks to show the main energy conversions that occurred. [1]

$\xrightarrow{\text{energy (in the stretched rubber band)}}$
 $\xrightarrow{\text{energy (in the moving rubber band)}}$
 $\xrightarrow{\text{energy (in the moving iron cube)}}$

- (b) State the relationship between the distance the rubber band was stretched back and the distance travelled by the iron cube. [1]

- (c) Without adding or removing any materials, suggest one way to make the iron cube travel a further distance on the surface of the wooden table, when the distance that the rubber band was stretched back to is 12 cm. [1]

(Go on to the next page)

| | |
|-------|---|
| SCORE | 3 |
|-------|---|

36. Patrick sets up the experiment as shown using identical apparatus.

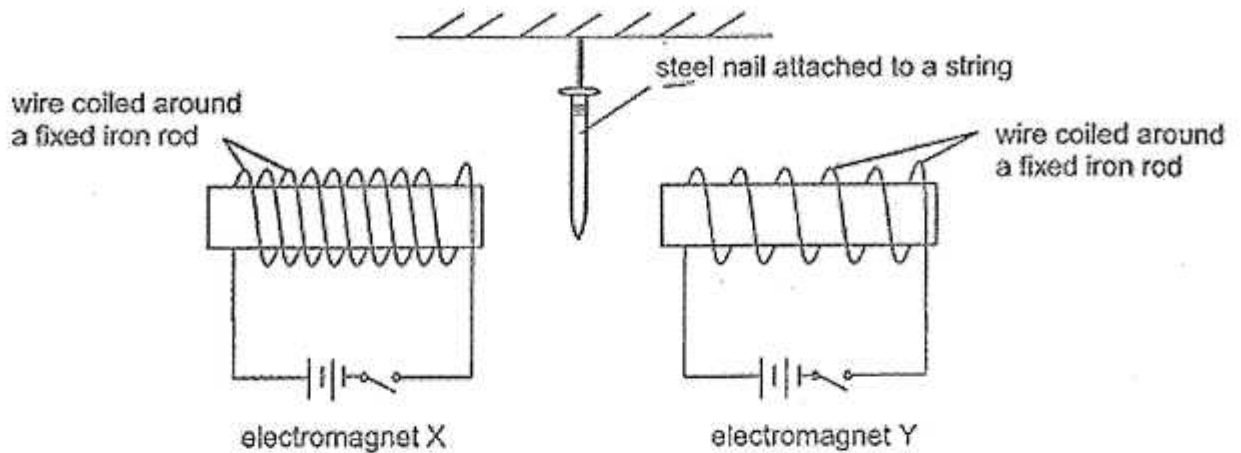

(a) What is the aim of Patrick's experiment? [1]

(b) When he closes the switches of both circuits at the same time, he observes that the steel nail moves towards one of the electromagnets. Which electromagnet, X or Y, does the steel nail move towards? Explain your answer. [2]

(c) Patrick wants to investigate if the material of the rod affects the strength of the electromagnet. State the change(s) he has to make to his set-up to investigate his new aim. [2]

(Go on to the next page)

| | |
|-------|---|
| SCORE | 5 |
|-------|---|

37. Mr Tan carried out an experiment on the floor of a classroom. He attached a 20 cm spring to a wall and placed a toy car next to it. When he pushed the toy car towards the wall and released it, the toy car moved forward.

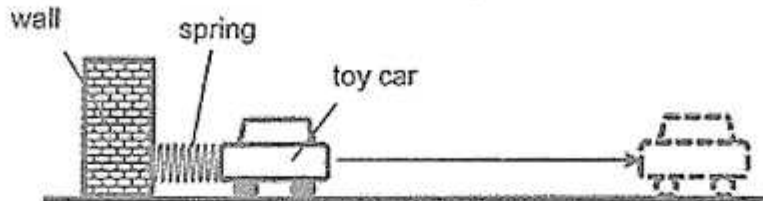

Mr Tan repeated his experiment by compressing the spring to different lengths and recorded the distances travelled by the toy car in the table.

| | | | |
|--|----|----|----|
| Length of compressed spring (cm) | 8 | 12 | 16 |
| Distance travelled by the toy car (cm) | 34 | 20 | 15 |

- (a) Why did Mr Tan use the same toy car throughout his experiment? [1]

- (b) Mr Tan poured some water on the floor and found that the toy car travelled a further distance when he repeated the experiment. Give a reason why. [1]

- (c) Mr Tan placed a ramp as shown.

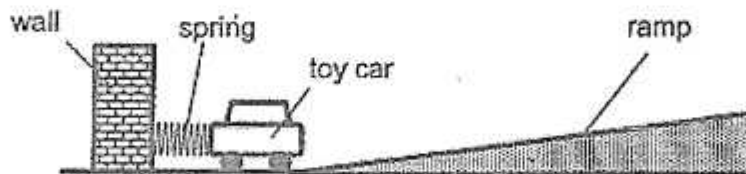

He released the toy car when the length of the compressed spring is 12 cm. Will the distance travelled by the toy car be more than, less than or remain at 20 cm? Explain your answer. [1]

(Go on to the next page)

| | |
|-------|---|
| SCORE | 3 |
|-------|---|

38. Fahim set up the experiment as shown. He wants to find out how the area of the sail of his toy boat affects the distance the toy boat travels across a pond with the fan turned on, which is placed 5 cm from the toy boat.

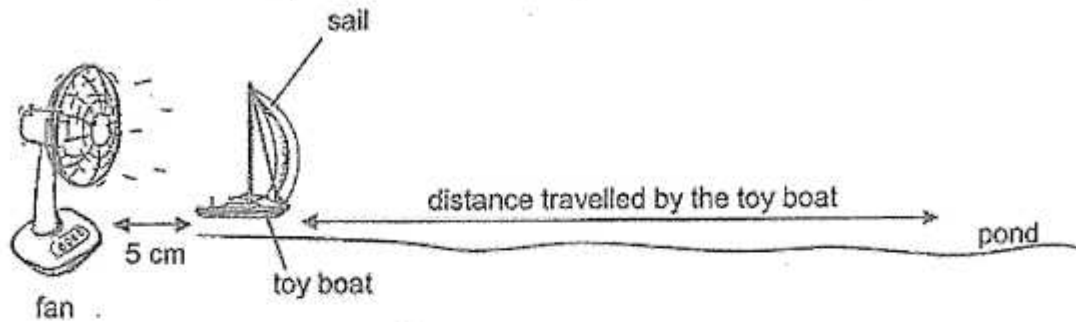

Fahim repeated the experiment with the same toy boat with different areas of sail and recorded the results in the table.

| | | | | |
|---------------------------------|----|----|----|----|
| Area of sail (cm ²) | 10 | 7 | 4 | 2 |
| Distance travelled (cm) | 50 | 38 | 20 | 12 |

- (a) State a property of the material that the sail of the toy boat must have to allow the toy boat to travel on water. [1]

- (b) Explain why the toy boat travelled a greater distance when the area of the sail is larger. [1]

- (c) State one improvement to the experiment to obtain a more accurate result. [1]

(Go on to the next page)

| | |
|-------|---|
| SCORE | 3 |
|-------|---|

39. Stan wants to find the volume of a stone using the following apparatus.

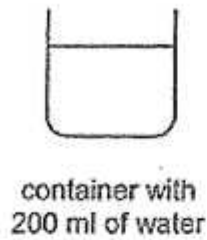

- (a) Describe how Stan can find the volume of the stone using the given apparatus. You may use a diagram in your answer. [2]

- (b) Using the property of matter, explain why your method in (a) works. [2]

(Go on to the next page)

| | |
|-------|---|
| SCORE | 4 |
|-------|---|

40. Sam set up the following solar still to obtain water from sea water.

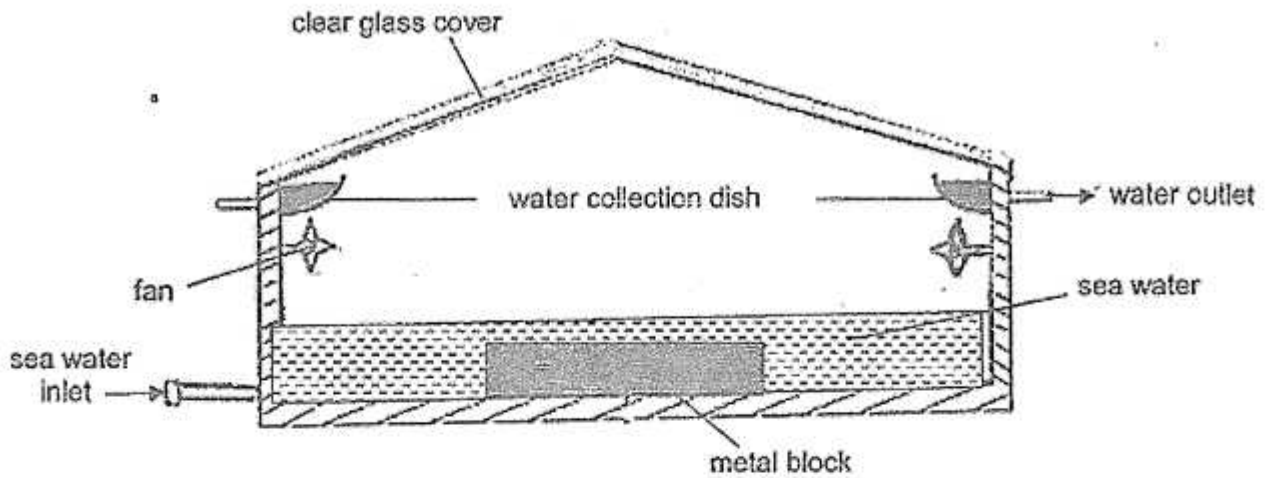

(a) State the purpose of the fans in the solar still. [1]

(b) Describe how water was collected in the water collection dish. [2]

(c) Sam noticed that less water was collected once the sea water level was the same height as the metal block or lower. Explain why. [1]

End of Paper

| | |
|-------|---|
| SCORE | 4 |
|-------|---|